



KEYPAD



ADA RULES

EN 81-70

Clavier numérique pour IRIS TOUCH.
Keypad for IRIS TOUCH.

FONCTIONS PRINCIPALES

- Caractères tactiles en relief.
- Caractère spécial pour l'entrée principale.
- Séquence téléphonique standard.
- Conforme aux normes ADA.
- Conforme à la norme EN81-70.
- Matériau: Zamak.
- Disponible en argent et noir.

MAIN FEATURES

- Tactile engraved characters.
- Special character for main entry floor.
- Standard telephone sequence.
- ADA Standards compliant.
- EN81-70 compliant.
- Material: Zama.
- Available in silver and black.

CARACTÉRISTIQUES TECHNIQUES / TECHNICAL FEATURES

- Connexion / Connection: RS485/USB.
- Alimentation / Power Supply: 12- 24 VDC.
- Durée / Durability: 3,000,000 operat. min.
- Force de fonctionnement / Operating force: 1.27 N (130 gf).



STANDARD
MODEL



SPECIAL
Accessibility design
model



Version noire /
black version



Version noire chiffres
or / black version
with gold legends

DIMENSIONS / DIMENSIONS

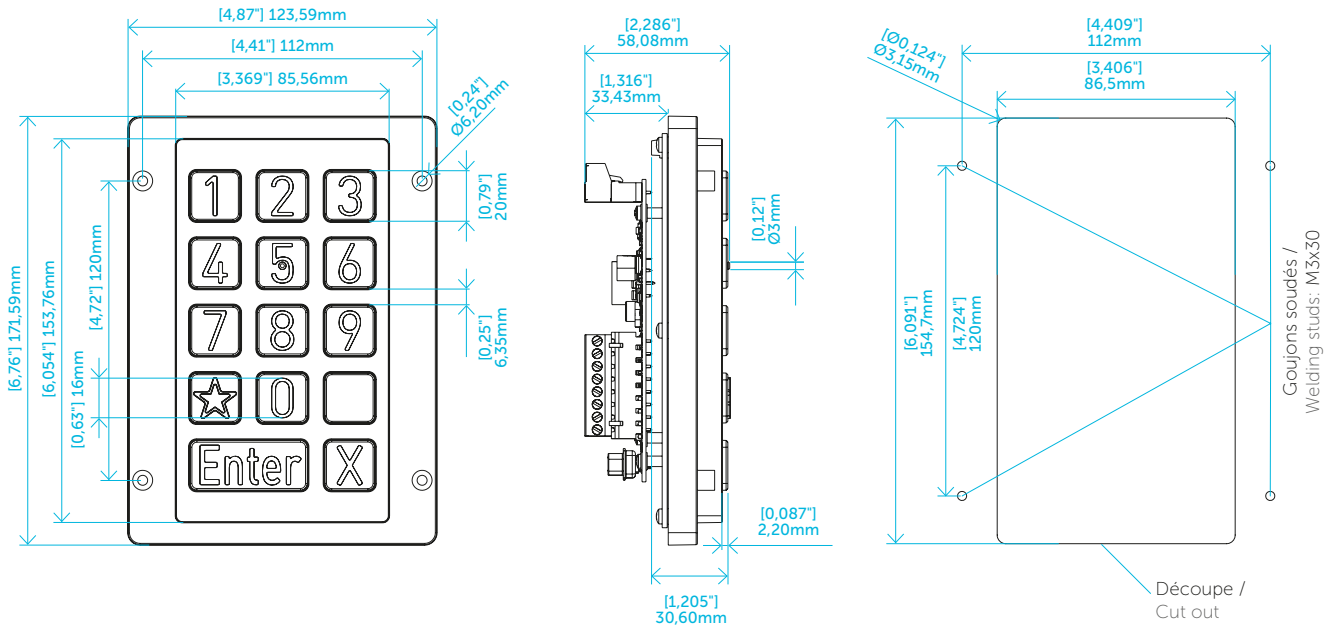

STANDARD MODEL

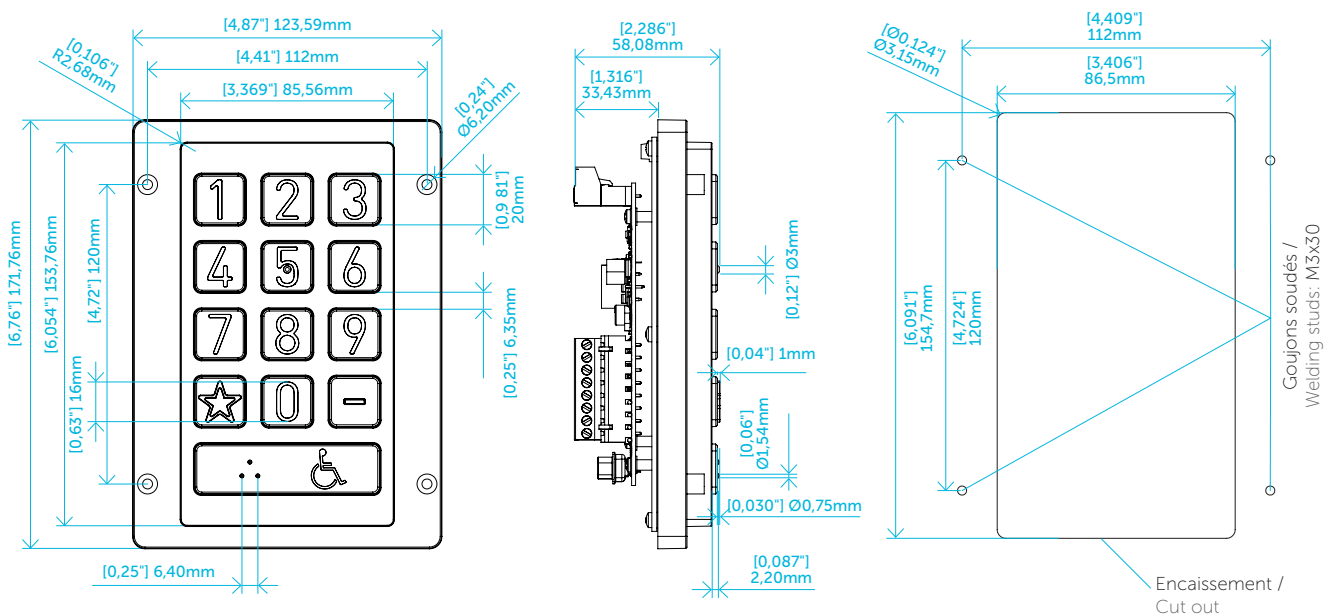

SPECIAL

Accessibility design model